

CDK II Carburetor Exploded View

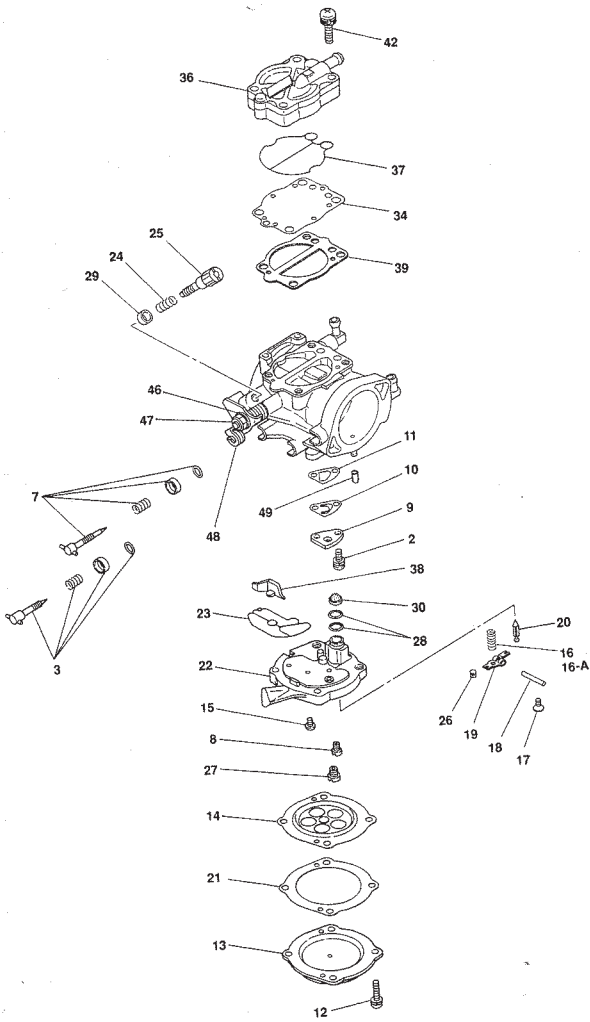

NOTE: Do not remove parts that are not shown on this exploded view.

CDK II with Accelerator Pump Exploded View

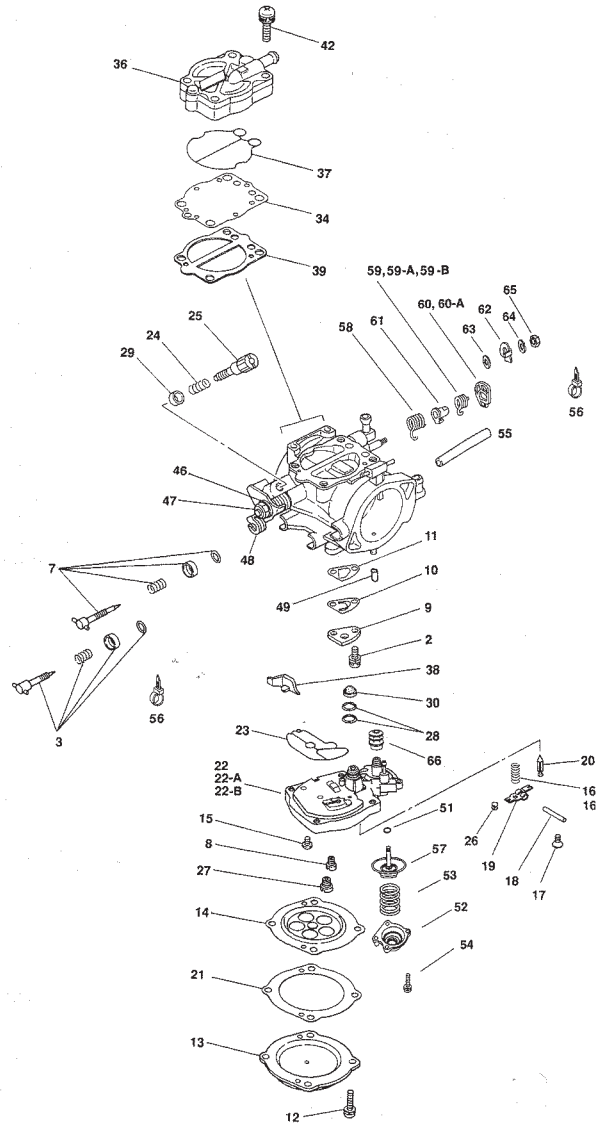

NOTE: Do not remove parts that are not shown on this exploded view.

CDKII Carburetor Parts List

NO.	DESCRIPTION	CDKII 38 & 42	CDKII 42 WITH ACCELERATOR PUMP
2	SCREW	N114-03060	<—
3	ADJUST SCREW (MAIN)	Z014-0660	<—
7	ADJUST SCREW (SLOW)	Z014-0670	<—
8	SLOW JET	N424-35XXX	<—
9	PLATE	1090-823-2000	<—
10	CHECK VALVE	1242-809-2000	<—
11	GASKET	1202-823-2000	<—
12	SCREW	0135-828-1900	<—
13	COVER	1230-827-2000	<—
14	DIAPHRAGM	1201-813-2100	<—
15	SCREW	93500-04008-1H	<—
16	COIL SPRING (70GRS)	1290-947-2000	1290-961-2000
16-A	COIL SPRING (40GRS)	1290-966-2000	1290-992-2000
17	SCREW	4114-001-1200	<—
18	ARM PIN	16152-KG8-9010-M1	<—
19	FLOAT ARM	1054-823-2000	<—
20	NEEDLE VALVE	1062-818-2000	<—
21	GASKET	1202-822-2000	<—
22	JET BLOCK 1.6VS	1605-829-2101-1.6	1605-859-2102-1.6 or 1605-837-2103-1.6
22-A	JET BLOCK 1.8VS	1605-829-2101-1.8	1605-859-2102-1.8 or 1605-837-2103-1.8
22-B	JET BLOCK 2.0VS	1605-829-2101-2.0	1605-859-2102-2.0 or 1605-837-2103-2.0
23	U-RING	0903-809-6000	<—
24	COIL SPRING	1290-050-2000	<—
25	STOP SCREW	1034-824-7000	<—
26	LEVER PIN	1480-049-2004	<—
27	MAIN JET	N424-36XXX	<—
28	O-RING	0901-055-6000	<—
29	COLLAR	1118-935-7000	<—
30	SCREEN	2009-811-2100	<—
34	DIAPHRAGM	1201-825-2000	<—
36	F. PUMP COMP.	1000-983-0400	<—
37	O-RING	0901-841-6000	<—
38	COLLAR	1118-964-7000	<—
39	GASKET	1202-851-2000	<—
42	SCREW	4129-826-1900	<—
46	SPRING WASHER	0303-801-1000	<—
47	LOCK NUT	0208-807-1000	<—
48A	TH. LEVER A	1026-952-2000	<—
48B	TH. LEVER B	1026-949-2001	<—
48C	TH. LEVER C	1026-951-2000	<—
48D	TH. LEVER D	1026-950-2000	<—
49	CAP	1096-047-2001	<—
50	SCREW	4110-812-1000	N/A
51	U-RING	N/A	W9353-40000
52	COVER, ACCP.	N/A	1230-845-2000
53	COIL SPRING, ACCP.	N/A	1290-987-2000
54	SCREW, ACCP.	N/A	0135-823-1000
55	RUBBER HOSE, (ACCP.)	N/A	0804-A93-0000
56	ZIP TIE	N/A	W3756-001-9900
57	DIAPHRAGM COMP, ACCP.	N/A	1201-829-2102
58	COIL SPRING FOR ACCEP.	N/A	1290-A02-2000
59	COIL SPRING FOR ACCEP. CAM	N/A	1305-990-2000
59-A	COIL SPRING FOR ACCEP. CAM	N/A	1305-991-2000 (+80% TENSION)
60	ACCP. CAM	N/A	1100-886-7000
60-A	ACCP. CAM	N/A	1100-889-7000 (-20% VOLUME)
61	COLLAR	N/A	1118-A11-7000
62	PLATE	N/A	1026-986-2000
63	PLAIN WASHER	N/A	0301-862-1000
64	SPRING WASHER	N/A	0303-801-1000
65	NUT	N/A	0208-801-1000
66	BOOTS	N/A	1028-054-7000

CDK Carburetor Repair Kit

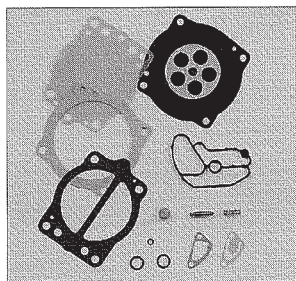

CDK 28MM REPAIR KIT					
PART No.	TYPE	No.	CONTENTS	YEAR	QTY
9000-981-0100	CDK 28MM	11	CHECK VALVE	ALL	1
		21	GASKET (DIAPHRAGM)	ALL	1
		20	NEEDLE VALVE	ALL	1
		19	FLOAT ARM	ALL	1
		10	CHECK VALVE	ALL	1
		8	SLOW JET	ALL	1
		14	DIAPHRAGM	ALL	1
		6	O-RING (ADJUST SCREW)	ALL	2
		23	U-RING	ALL	1
		10	MAIN JET	ALL	1
		16	SPRING (NEEDLE VALVE)	ALL	1
		28	O-RING (NEEDLE SEAT)	'86 '87	1
		28	O-RING (NEEDLE SEAT)	'88 '89 '90	2

POLARIS1

Hurricane
SLT1050
SL700
SL900

KAWASAKI1

Eng. Displacement 750cc Plus
From '94 Model to Present

KAWASAKI2, A/M 38, 42MM

Other than the Kawasaki1 aftermarket
38 & 42MM

POLARIS2

SL1050

AM 42 W/ACCP.

Aftermarket 42MM with Accelerator Pump

NOTE: #55 & #56 are for mid range parts.
This kit includes enough quantity of the parts for triple carburetor. Single or dual carburetor user will have some extra parts.

CDKII 38, 40, 42MM REPAIR KIT					APPLICATION				
KIT PART No.	TYPE	No.	CONTENTS	INDIVIDUAL PART No.	Q'TY	KAWASAKI1	PCLARIS2	KAWASAKI2	A/M 42
						POLARIS1	REQ'D Q'TY	REQ'D Q'TY	REQ'D Q'TY
1000-A47-0100	CDKII 38, 40, 42MM	10	CHECK VALVE	1242-811-2000	1	***	***	---	---
		10	CHECK VALVE	1242-809-2000	1	---	---	---	---
		23	U-RING	0903-810-6000	1	***	***	---	---
		23	U-RING	0903-809-6000	1	---	---	---	---
		16	COIL SPRING	1290-961-2000	1	***	---	---	---
		16	COIL SPRING	1290-A03-2000	1	---	***	---	---
		16	COIL SPRING	1290-947-2000	1	---	---	---	---
		11	GASKET (CHECK VALVE)	1202-823-2000	1	***	***	***	***
		14	DIAPHRAGM COMP.	1201-813-2100	1	***	***	***	***
		21	GASKET	1202-822-2000	1	***	***	***	***
		20	NEEDLE VALVE	1062-818-2000	1	***	***	***	***
		28	O-RING	0901-055-6000	2	***	***	***	***
		30	SCREEN	2009-811-2100	1	***	***	***	***
		34	DIAPHRAGM	1201-825-2000	1	***	***	***	***
		37	O-RING	0901-841-6000	1	***	***	***	***
		39	GASKET	1202-851-2000	1	***	***	***	***
		55	CHECK VALVE (Mid Range)	1242-810-2000	1	***	***	---	---
56	GASKET (MID RANGE)	1202-857-2000	1	***	***	---	---		